



PEACE OF MIND IN A DANGEROUS WORLD

XIP3322B: HKDF/HMAC/SHA-256

SHA-256 IP Core with Extended Functionalities

Product Brief
ver. 1.0
September 20, 2023

sales@xiphera.com

Introduction

XIP3322B from Xiphera is a versatile Intellectual Property (IP) core designed for SHA-256 cryptographic hash function with extended support for HMAC message authentication code and HKDF key derivation function that are based on using SHA-256. SHA-256 is one of the most commonly used hash functions and is used in numerous cryptographic applications. XIP3322B offers a good balance between performance and resource requirements.

XIP3322B has been designed for easy integration with FPGA- and ASIC-based designs in a vendor-agnostic design methodology, and the functionality of XIP3322B does not rely on any FPGA manufacturer-specific features.

Key Features

- **Versatility:** XIP3322B supports the widely used cryptographic hash function SHA-256. It also has native support for commonly used message authentication code (HMAC) based on SHA-256 and key derivation function (HKDF) based on HMAC. This allows using XIP3322B for multiple cryptographic functions—for example, TLS 1.3 [4]—more easily and efficiently than an IP core that supports only SHA-256.
- **Constant Latency:** The execution time of XIP3322B is independent of the message and key values (apart from message length), and consequently provides protection against timing-based side-channel attacks.
- **Performance:** XIP3322B provides high performance and reaches hashing speeds of several hundreds of Mbps.
- **Compact Size:** XIP3322B has compact size (for example, 2779 4LUTs and, 3/4 uSRAM/LSRAM blocks in Microchip® PolarFire® family) permitting integration into resource constrained Microchip® FPGA designs.

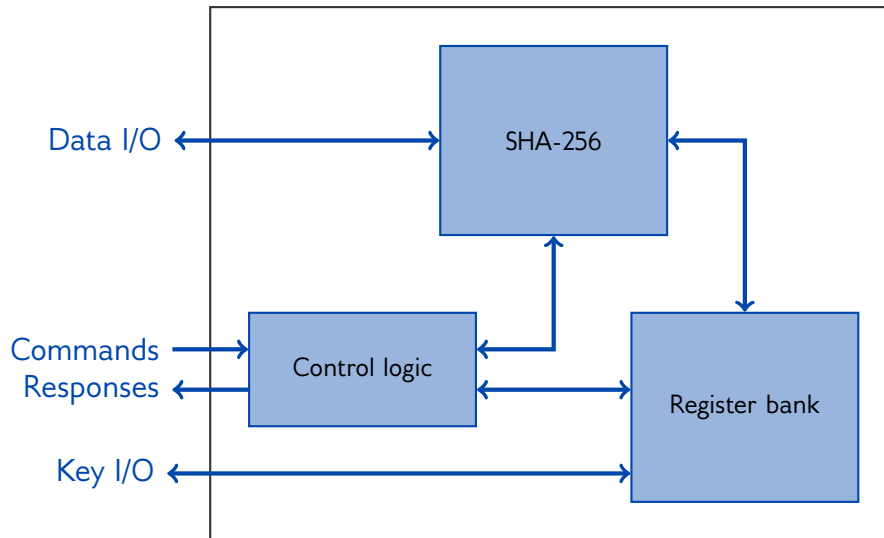

Figure 1: Internal high-level block diagram of XIP3322B

- **Standard Compliance:** XIP3322B is compliant with NIST FIPS 180-4 Secure Hash Standard (SHS) [2], FIPS 198-1 The Keyed-Hash Message Authentication Code (HMAC) [1], and RFC 5869 HMAC-based Extract-and-Expand Key Derivation Function (HKDF) [3]. Consequently, XIP3322B can be used in multiple cryptographic applications.

Functionality

XIP3322B supports four main functionalities:

- **SHA-256:** Computes a SHA-256 hash for an input message.
- **HMAC:** Computes an HMAC authentication tag for an input message using an authentication key.
- **HKDF-extract:** Computes the HKDF-extract function that calculates a pseudorandom key from initial key material.
- **HKDF-expand:** Computes the HKDF-expand function that expands the pseudorandom key to several additional pseudorandom keys of desired lengths for specific cryptographic algorithms.

XIP3322B has a convenient 32-bit FIFO interface allowing for easy integration with rest of the FPGA design. The data inputs are loaded into XIP3322B with byte-level granularity using the `numbytes` signal that denotes the number of active bytes in a 32-bit word (0...4). The key inputs are loaded through a separate port allowing full isolation between keys and data.

Block Diagram

The internal high-level block diagram of XIP3322B is depicted in Figure 1.

Interfaces

The external interfaces of XIP3322B are depicted in Figure 2.

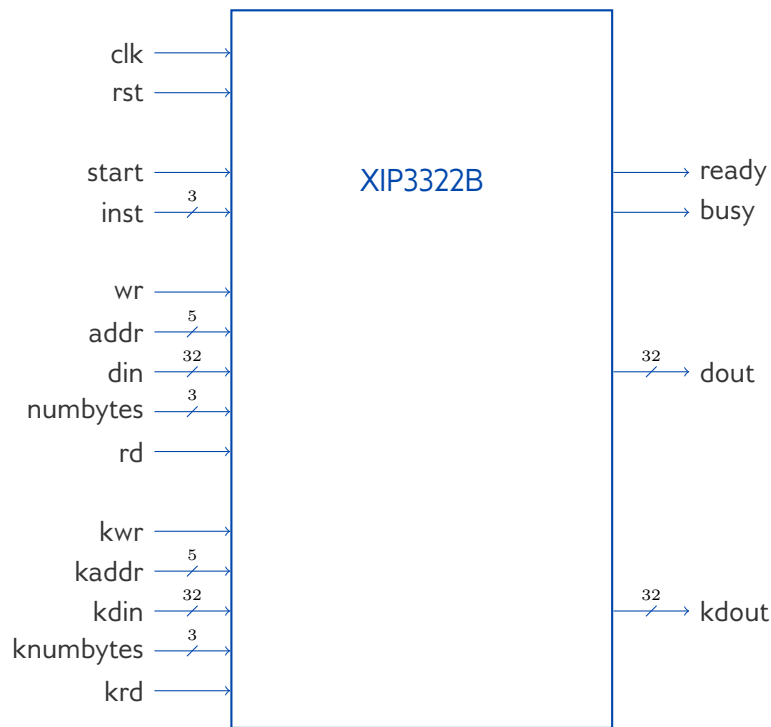

Figure 2: External interfaces of XIP3322B

This Product Brief describes a high-level overview of the functionality and capabilities of XIP3322B. Please contact sales@xiphera.com for a complete datasheet with a detailed description of the input and output signals, startup procedure of XIP3322B, example simulation waveforms, and the FPGA resource requirements of your targeted FPGA family.

FPGA Resources and Performance

Table 1 presents the Microchip® FPGA resource requirements for certain Microchip® FPGAs. On request, the resource estimates can also be supplied for other Microchip® FPGA families.

Device	Resources	f_{MAX}
Microchip® PolarFire® *	2779 4LUT, 3/4 uSRAM/LSRAM	97.10 MHz

Table 1: Resource usage and performance of XIP3322B on representative Microchip® FPGA families.

The general performance characteristics for different functionalities are as follows:

- **SHA-256:** XIP3322B can perform SHA-256 hash computations with an asymptotic maximum throughput of $\frac{f_{MAX} * 512 \text{ bits}}{72}$ and minimum latency of 83 clock cycles (for at most 64 bit messages).

*Libero 2022.1.0.10, default compilation settings, industrial speedgrade.

- **HMAC:** An authentication tag computation requires two iterations of SHA-256, but the throughput of the computation approaches the throughput of SHA-256 for long messages.
- **HKDF:** HKDF-Extract and HKDF-Expand both require computation of a single HMAC and their performance is similar to HMAC with short messages.

Ordering and Deliverables

Please contact sales@xiphera.com for pricing and your preferred delivery method. XIP3322B can be shipped in a number of formats, including netlist, source code, or encrypted source code. Additionally, synthesis scripts, a comprehensive testbench, and a detailed datasheet including an integration guide are included.

About Xiphera

Xiphera specializes in secure and efficient implementations of standardized cryptographic algorithms on Field Programmable Gate Arrays (FPGAs) and Application Specific Integrated Circuits (ASICs). Our fully in-house designed product portfolio includes individual cryptographic Intellectual Property (IP) cores, as well as comprehensive security solutions built from a combination of individual IP cores.

Xiphera is a Finnish company operating under the laws of the Republic of Finland, and is fully owned by Finnish citizens and institutional investors.

Contact

Xiphera Oy
Tekniikantie 12
FIN-02150 Espoo
Finland
sales@xiphera.com
+358 20 730 5252

References

- [1] NIST Computer Security Division. FIPS PUB 198-1, The Keyed-Hash Message Authentication Code (HMAC). Technical report, National Institute of Standards & Technology, Gaithersburg, MD, United States, 2008.
- [2] NIST Computer Security Division. FIPS PUB 180-4 Secure Hash Standard (SHS). Technical report, National Institute of Standards & Technology, Gaithersburg, MD, United States, 2015.
- [3] Dr. Hugo Krawczyk and Pasi Eronen. HMAC-based Extract-and-Expand Key Derivation Function (HKDF). RFC 5869, May 2010.
- [4] Eric Rescorla. The Transport Layer Security (TLS) Protocol Version 1.3. RFC 8446, August 2018.